

Breather Valves

Brass

SPECIFICATION

Types

- Type **A**: Low design
- Type **B**: High design, with stainless steel cap

Valve body

Brass **MS**

Ball

Steel AISI 5210

Spring

Stainless Steel AISI 301

Seal DIN 7603 A

Soft iron 1.0338

(for $d_1 = M10 \times 1:PA6$)

Breather cap (Type B)

Stainless steel AISI 304

Temperature resistant from $-30\text{ }^\circ\text{C}$ to $+200\text{ }^\circ\text{C}$

INFORMATION

Once the opening pressure given in the table is exceeded, GN 883 breather valves will vent into a container and so protect against excessive inside container pressure. They also feature highly compact dimensions.

A coding (Type A) or a color ring (Type B) in yellow (20 - 80 mbar) or green (160 - 240 mbar) indicates the different opening pressure ratings.

The simple function principle (pressure spring / ball) ensures long and trouble-free use of the valve acting to one side. The installation position is vertical to the top.

TECHNICAL INFORMATION

- Stainless Steel characteristics (see page A26)



Type A

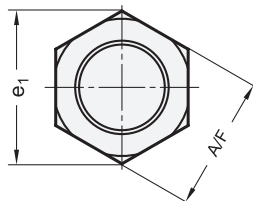
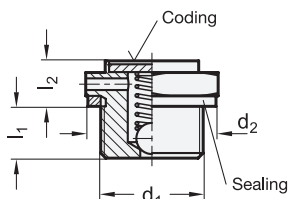

Type B

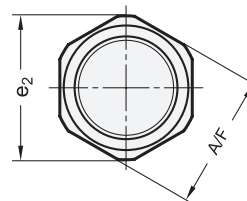
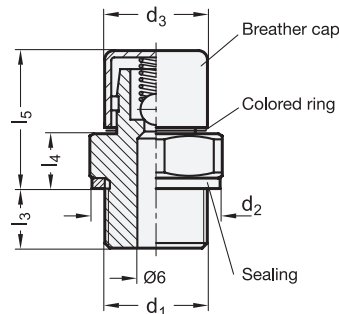



GN 883

Description	d1	Opening pressure in mbar min.	Opening pressure in mbar max.	d2	d3	e1	e2	l1	l2	l3	l4	l5	A/F	Ca. air passage l/min.	
GN 883-M10x1-20-A-MS	M 10 x 1	20	80	14.5	-	16	-	6	6	-	-	-	14	12	8
GN 883-M10x1-160-A-MS	M 10 x 1	160	240	14.5	-	16	-	6	6	-	-	-	14	12	8
GN 883-M12x1.5-20-A-MS	M 12 x 1.5	20	80	18	-	19.5	-	6.5	6	-	-	-	17	12	14
GN 883-M12x1.5-160-A-MS	M 12 x 1.5	160	240	18	-	19.5	-	6.5	6	-	-	-	17	12	14
GN 883-M14x1.5-20-A-MS	M 14 x 1.5	20	80	20	-	19.5	-	6.5	6	-	-	-	17	12	16
GN 883-M14x1.5-160-A-MS	M 14 x 1.5	160	240	20	-	19.5	-	6.5	6	-	-	-	17	12	17
GN 883-M16x1.5-20-A-MS	M 16 x 1.5	20	80	22	-	25	-	9	11	-	-	-	22	12	35
GN 883-M16x1.5-160-A-MS	M 16 x 1.5	160	240	22	-	25	-	9	11	-	-	-	22	12	36
GN 883-M10x1-20-B-MS	M 10 x 1	20	80	-	12.5	-	18.5	-	-	8	7	16	17	18	19
GN 883-M10x1-160-B-MS	M 10 x 1	160	240	-	12.5	-	18.5	-	-	8	7	16	17	18	19
GN 883-M12x1.5-20-B-MS	M 12 x 1.5	20	80	-	12.5	-	18.5	-	-	7.5	7	16.5	17	18	22
GN 883-M12x1.5-160-B-MS	M 12 x 1.5	160	240	-	12.5	-	18.5	-	-	7.5	7	16.5	17	18	22
GN 883-M14x1.5-20-B-MS	M 14 x 1.5	20	80	-	12.5	-	18.5	-	-	7.5	7.5	16.5	17	18	25
GN 883-M14x1.5-160-B-MS	M 14 x 1.5	160	240	-	12.5	-	18.5	-	-	7.5	7.5	16.5	17	18	25
GN 883-M16x1.5-20-B-MS	M 16 x 1.5	20	80	-	12.5	-	24	-	-	7.5	7.5	16.5	22	18	36
GN 883-M16x1.5-160-B-MS	M 16 x 1.5	160	240	-	12.5	-	24	-	-	7.5	7.5	16.5	22	18	36
GN 883-G1/4-20-A-MS	G 1/4	20	80	20	-	19.5	-	6.5	6	-	-	-	17	12	15
GN 883-G1/4-160-A-MS	G 1/4	160	240	20	-	19.5	-	6.5	6	-	-	-	17	12	15
GN 883-G3/8-20-A-MS	G 3/8	20	80	23	-	25	-	9	11	-	-	-	22	12	37
GN 883-G3/8-160-A-MS	G 3/8	160	240	23	-	25	-	9	11	-	-	-	22	12	35
GN 883-G1/2-20-A-MS	G 1/2	20	80	26	-	31	-	8.5	11	-	-	-	27	12	46
GN 883-G1/2-160-A-MS	G 1/2	160	240	26	-	31	-	8.5	11	-	-	-	27	12	54
GN 883-G3/4-20-A-MS	G 3/4	20	80	32	-	37	-	8.5	11	-	-	-	32	12	49
GN 883-G3/4-160-A-MS	G 3/4	160	240	32	-	37	-	8.5	11	-	-	-	32	12	83
GN 883-G1/4-20-B-MS	G 1/4	20	80	-	12.5	-	18.5	-	-	7.5	7.5	16.5	17	18	24
GN 883-G1/4-160-B-MS	G 1/4	160	240	-	12.5	-	18.5	-	-	7.5	7.5	16.5	17	18	24
GN 883-G3/8-20-B-MS	G 3/8	20	80	-	12.5	-	24	-	-	7.5	7.5	16.5	22	18	38
GN 883-G3/8-160-B-MS	G 3/8	160	240	-	12.5	-	24	-	-	7.5	7.5	16.5	22	18	38
GN 883-G1/2-20-B-MS	G 1/2	20	80	-	12.5	-	29	-	-	8	8	17	27	18	56
GN 883-G1/2-160-B-MS	G 1/2	160	240	-	12.5	-	29	-	-	8	8	17	27	18	56
GN 883-G3/4-20-B-MS	G 3/4	20	80	-	12.5	-	35	-	-	8	8	17	32	18	84
GN 883-G3/4-160-B-MS	G 3/4	160	240	-	12.5	-	35	-	-	8	8	17	32	18	84

Accessories for hydraulic systems 15